



**Science.
Applied to Life.™**

Electrical Solutions you can rely on.

Medium Voltage Cable Accesories



3M for Electronic & Energy

3M's Electrical Markets Division (EMD) has been designing and manufacturing electrical products for more than 60 years, including electrical tapes and mastics, wire connectors and tools, cable accessories, splices and terminations, heat shrinkable and cold shrink sealing and insulating products, and highcapacity transmission conductors (ACCR). Some of our other products help protect, assess and renew the world's water and energy infrastructure. These include powder and liquid coatings for water, gas and oil pipelines, linings for rehabilitating water pipes, and products for marking and locating assets.

That's 3M Science. Applied to life.™

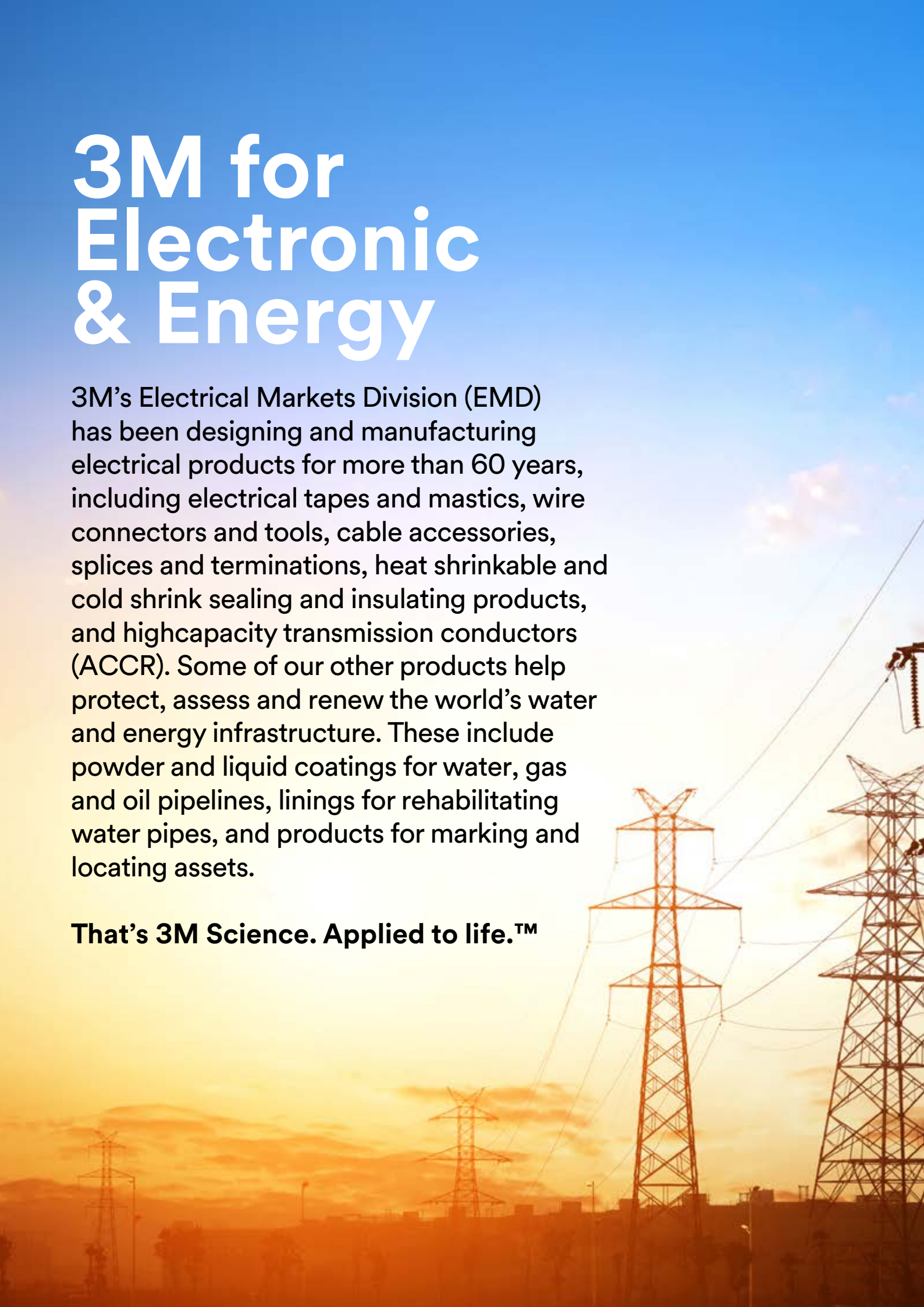



TABLE OF CONTENTS

Medium Voltage Cable Accesories Cold Shrink Technology	02
Silicone Rubber Cold Shrink Termination Kits - QTII (X) Series	04
Production Description	
Production Application	
Selection Guide	
Key Features	
Detailed composition	
Silicone Rubber Cold Shrink Termination Kits - QTIII (X) Series	08
Production Description	
Production Application	
Selection Guide	
Key Features	
Detailed composition	
Medium Voltage Terminations Heat Shrink Tecnology (MHO/MHI Series)	13
Production Description	
Production Application	
Selection Guide	
Key Features	
Detailed composition	
Tape Resin Splice VN-5B & 6B	18
Production Description	
Production Application	
Selection Guide	
Key Features	
Detailed composition	
Cold Shrink Inline Joint with Heat-Shrink Re-jacketing 3M™ QS 2000E	28
Production Description	
Production Application	
Selection Guide	
Key Features	
Detailed composition	
Cold Shrink Inline Joint 3M™ QS 200	30
Production Description	
Production Application	
Selection Guide	
Key Features	
Detailed composition	
Cold Shrink Inline Joint 3M™ QS 3000	36
Production Description	
Production Application	
Selection Guide	
Key Features	
Detailed composition	

Over 40 years ago, 3M pioneered cold shrink technology. Since then, field use and laboratory analysis have repeatedly proven its merits and reliability. Through constant innovation, we have refined cold shrink products making them better than ever. They're easier to apply and built to withstand some of the most punishing environmental conditions. Enhanced performance at a lower installed cost continues to make 3M the preferred choice for cold shrink solutions.

Why move to 3M Cold Shrink?

- ▶ Fast, straightforward installation.
- ▶ No flame required.
- ▶ No special site permits needed.
- ▶ No cooling time needed before energising.
- ▶ Easier to use in enclosed areas.
- ▶ Constant radial pressure for optimised environmental performance.
- ▶ Less chance of damaging XLPE cable material.
- ▶ Extensive quality and factory testing programmes.

These cold shrink terminations are lightweight for either free-hanging or bracket mounting arrangements. 3M offers you two options for choosing a cold shrink termination. The QT- III termination utilizes the latest technology with built-in Hi-K stress controlling mastic and environmental sealing mastic resulting in a much more user-friendly application that reduces chances of errors.

3M™ Cold Shrink QT-II and QT-III Terminations are designed using 3M developed track-resistant silicone rubber and Hi-K stress control material in conjunction with 3M's unique cold shrink delivery system.

Terminations are supplied prestretched on a removable core. Removal of the core by unwinding after positioning the termination allows the product to shrink into position, providing a living seal.

QT-II and QT-III cold shrink silicone rubber is specifically formulated as a high track-resistant material with hydrophobicity (water repelling action) and UV resistance to ensure a longlife expectancy when properly installed.

The QT-II termination offers some of the same advantages as the QT-III termination but without a few of the integrated features that the QT-III termination possesses. All terminations meet or exceed IEEE 48, IEC 60502-4 and CENELEC 629-1 (replaced VDE 0278) requirements.



Medium Voltage Cable Accessories

Cold Shrink Technology



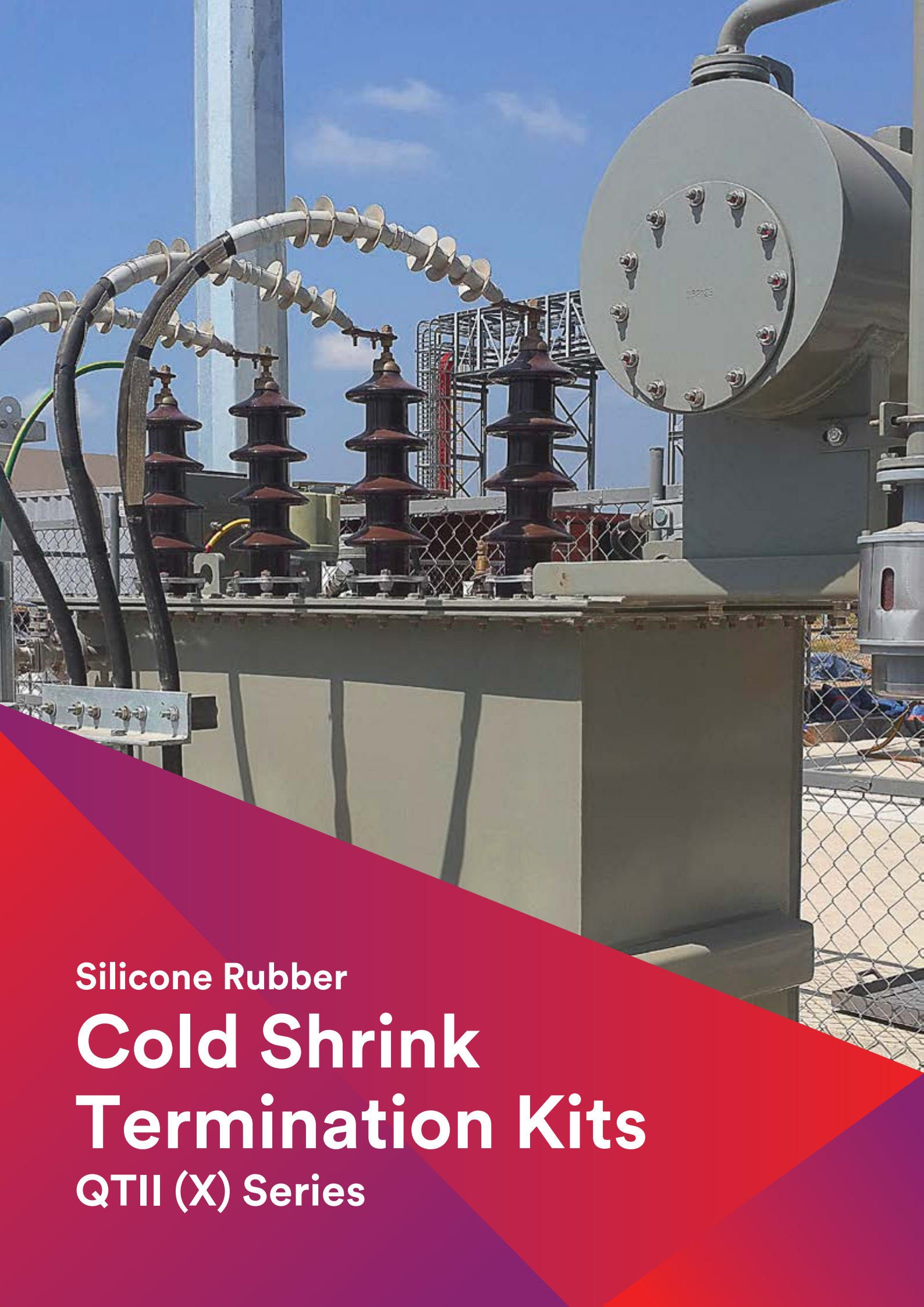

Silicone Rubber

Cold Shrink Termination Kits

QTII (X) Series

PRODUCTION DESCRIPTION

The 3M QTII (X) Series are Silicone Rubber Cold Shrink Quick Terminating System that designed to accommodate medium voltage metallic-shielded armored non-armored, copper or aluminum conductor power cables configurations.

3M QTII (X) Series provide easy installation for indoor and outdoor applications. QT-II (X) termination is based on specially formulated, track-resistant silicone rubber insulators with built-in Hi-K stress relief. The insulators are prestretched around a spiral -wound, plastic core.

The QTII (X) Series Termination meet or exceed the specification requirements of Standards:

- ▶ IEEE Standard 48-1990, for Class 1 termination.
- ▶ CENELEC Standards HD 628-S1 and HD 629.1.S1.
- ▶ VDE Standard 0278-628 and VDE 0278-629-1.
- ▶ British Standard BS 7888-4.1.
- ▶ IEC Standard 61442 & 60502-4.
- ▶ Vietnamese Standard TCVN 5935-4.



PRODUCTION APPLICATION

- ▶ For power cables up to 42kV.
- ▶ For polymeric cables: polyethylene, XLPE, EPR.
- ▶ For 1C/ 3C copper tape, wire shield, armored/ non-armored power cables.
- ▶ For copper or aluminum conductors.
- ▶ For contaminated, pollution area, operating environment.
- ▶ For switchgear, transformer, motor lead (terminal type) bus, overhead etc. connections.



SELECTION GUIDE

	6/10(12) kV		12.7/22(24) kV		20/35(40.5) kV		22/38.5(42) kV	
	ID	OD	ID	OD	ID	OD	ID	OD
4-Skirt	✓	✓	✓					
6-Skirt				✓	✓			
8-Skirt						✓		
12-Skirt							✓	✓

KEY FEATURES

- ▶ Versatile- Install quickly and accommodates a wide range of cable sizes: from 25sqmm to 630sqmm.
- ▶ Simple hand application, no need for special installation tools.
- ▶ No torches or heat required.
- ▶ Excellent resistance to ozone and UV radiation.
- ▶ Good solvent resistant.
- ▶ Excellent thermal stability.
- ▶ High dry and wet insulation resistance.
- ▶ High flexible - accommodates all cable company bend radius recommendations.
- ▶ Reliable Seals - Termination assemblies retain resiliency and cable interface pressure after prolonged years of aging and exposure.

QTII (X) Series

DETAILED COMPOSITION OF THE QTII (X)

▶ QTII Termination Assembly:

The cold shrink delivery system has repeatedly proven itself to be unsurpassed as a positive and reliable electrical insulating and moisture-sealing system for cable primary insulation interface surface.

One-piece cold shrink termination assembly is created when silicon rubber skirted insulator is mounted over a High Dielectric Constant (High-K) stress relief on a common support core.

SILICONE RUBBER-MATERIAL CHARACTERISTICS

- ▶ **Smooth surface:** minimum amount of contamination adhere to the termination.
- ▶ **Hydrophobicity:** When water comes in contact with the silicone it beads up and runs off the skirts rather than completely wetting these surfaces. Thus a less conductive path is formed on the silicone and leakage currents are lowered.
- ▶ **Non-organic/ nonconductive:** degrade leakage current and arcing occurs on the surface of termination.
- ▶ **High temperature with stand:** An outstanding physical characteristic of silicone rubber is its retention of desirable properties over the wide temperature range of 100°C to 180°C.

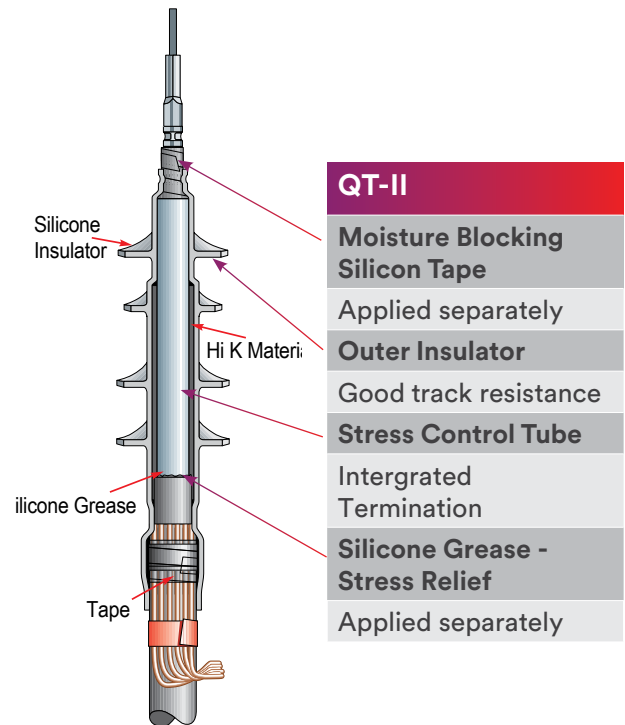

NOTE: Length of phases depend on requirements of Customer. Installed length of 3-phase 3M QTII termination standard kits are 1m approximate.

SELECTION GUIDE

	6/10(12) kV		12.7/22(24) kV		20/35(40.5) kV		22/38.5(42) kV	
	Indoor/ Outdoor	Indoor	Outdoor	Indoor	Outdoor	Indoor	Outdoor	
1-phase	QTII (X)4S-11	QTII (X)4S-12	QTII (X)6S-12	QTII (X)6S-13	QTII (X)8S-13	QTII (X)8S-14	QTII (X)12S-14	
3-phase	QTII (X)4S-31	QTII (X)4S-32	QTII (X)6S-32	QTII (X)6S-33	QTII (X)8S-33	QTII (X)8S-34	QTII (X)12S-34	

QTII (X)xS-CV

- QTII** : Product Name Quick Termination II
(X)xS : Type of QTII termination/body assembly (J4S, L6S, M8S; S: Skirt)
C : Number of Conductor/ Core (1, 3)
V : Class of Voltage (1: 12kV; 2: 24kV; 3: 36kV, 4: 40.5kV)

Ex.: QTII (L)6S-32 is QTII 3/C termination, body type L 6S, outdoor application for 24kV class, 100°C to 180°C.

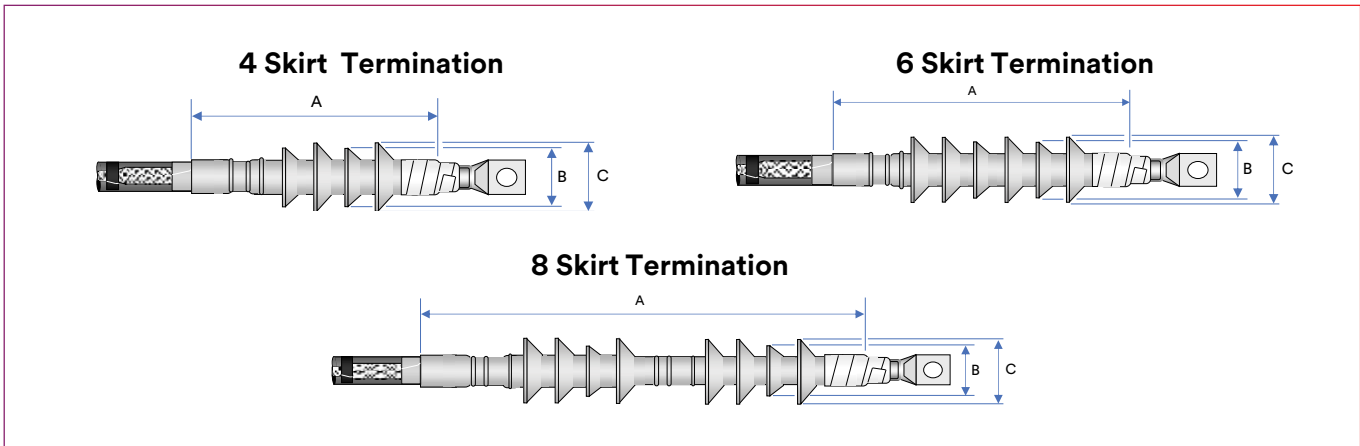

Number of QTII body	Cable Application Range			Dimensions (mm)				
	O.D. insulation (mm)		O.D. Jacket (mm)	Installed length (A)	Installed length (B)	Installed length (C)	Creepage Distance (1P/3P)	Arcing Distance
	Min	Max						
4 SKIRT								
J	16.3	22.9	20.3 - 30.5	250	42.4	68.1	438 / 1138	317
K	21.3	33.8	25.4 - 40.6	250	46.2	69.8	438 / 1138	317
L	27.9	41.9	33.0 - 48.3	275	50.8	82.5	489 / 1189	356
M	33.0	49.5	38.1 - 61.0	280	50.8	90.2	495 / 1195	362
6 SKIRT								
J	16.3	22.9	20.3 - 30.5	325	42.4	68.1	584 / 1284	394
K	21.3	33.8	25.4 - 40.6	325	46.2	69.8	584 / 1284	394
L	27.9	41.9	33.0 - 48.3	360	50.8	82.5	654 / 1354	432
M	33.0	49.5	38.1 - 61.0	370	50.8	90.2	660 / 1360	438
8 SKIRT								
J	16.3	22.9	20.3 - 30.5	325	42.4	68.1	584 / 1284	394
K	21.3	33.8	25.4 - 40.6	325	46.2	69.8	584 / 1284	394
L	27.9	41.9	33.0 - 48.3	360	50.8	82.5	654 / 1354	432
M	33.0	49.5	38.1 - 61.0	370	50.8	90.2	660 / 1360	438

Termination Identification & Markings

Termination Body Size
Available sizes are J, K, L & M

Production Date Code Indicator
A dash in 2 quadrants denotes 2nd quarter, etc.

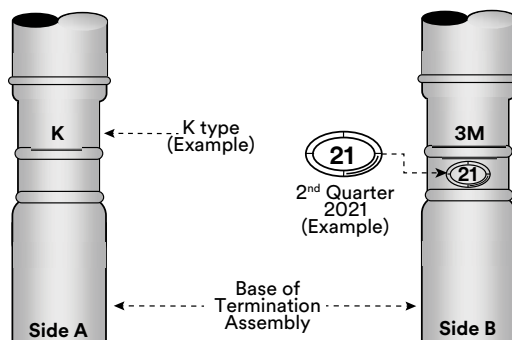



Silicone Rubber

Cold Shrink Termination Kits

QTIII (X) Series

PRODUCTION DESCRIPTION

The 3M Cold Shrink QT-III Silicone Rubber Skirted Termination Kits, 7620-S, 7680-S and 7690-S Series, contain one-piece, skirted, silicone rubber terminations, and two-piece, Inverted Skirted, silicone rubber terminations, qualified as IEEE Standard 48 Class 1 for outdoor weather-exposed applications. The one-piece termination assemblies consist of a skirted insulator, high-dielectric constant (High-K) stress control tube*, conformable High-K stress controlling compound and built-in environmental top sealing compound. The two-piece inverted skirted termination assemblies consist of a non-skirted (tubular) insulator, high-dielectric constant (High-K) stress control tube, conformable High-K stress controlling compound, built-in environmental top sealing compound and a separate skirted assembly. The insulators and separate skirted assemblies are made of a dark gray silicone rubber with excellent tracking resistance and hydrophobic properties. *7620-S is designed and assembled with stress controlling compound only. The complete assembly is pre-stretched and loaded onto a removable core. The disposable core can be recycled. The kits are designed for terminating solid dielectric shielded power cables rated 5 through 35kV, with Tape Shield, Wire Shield and UniShield® constructions.

PRODUCTION APPLICATION

3M Cold Shrink QT-III Silicone Rubber Skirted and Inverted Skirted Termination Kits, 7620-S, 7680-S and 7690-S Series are designed for:

- ▶ 5, 8, 15, 25/28 and 35kV classes.
- ▶ Tape Shield, Wire Shield and UniShield® cables.
- ▶ Solid dielectric insulations, such as polyethylene, XLPE and EPR.
- ▶ Protected and weather-exposed contaminated locations.
- ▶ Free-hanging or bracket-mounting arrangements.
- ▶ Upright or inverted installation arrangements available.
- ▶ Inverted termination kits are available in limited versions, but cover 5kV to 35kV classes.
- ▶ These terminations can be field tested using normal cable testing procedures (reference: ANSI/IEEE Standard 400 “Guide for Field Testing and Evaluation of the Insulation of Shielded Power Cable Systems.” Refer to most recent version).

The amount of airborne contamination determines the operating environment. Operating environments are described as areas having varying degrees of airborne contaminant or pollution severity that may, or may not, affect the long-term performance of terminations. These operating environments are defined as light, medium, heavy and extremely heavy variations according to pollution severity. The appropriate termination selection depends on the system voltage and operating environment. (See following tables)

KEY FEATURES

Conforms to the IEEE Standard 48 Class 1 requirements for 5, 8, 15, 25/28 and 35kV terminations. One-piece, and two-piece inverted skirted, versatile designs, allowing quick installation and accommodating a wide range of cable sizes. Cold Shrink delivery system for easy installation: Simply place termination over prepared cable and unwind core to shrink into place (no force fit required) High-K stress control: Specially formulated high dielectric constant material minimizes surface stress by more uniformly distributing the electrical field over the entire surface of the insulator. Compact design provides for easier installation in restricted spaces.

Silicone rubber insulators, EPDM stress control tubes, stress controlling compound and environmental sealing compound are compatible with all common solid dielectric insulations, such as polyethylene (PE), cross-linked polyethylene (XLPE) and ethylene propylene rubber (EPR).



DETAILED COMPOSITION OF THE QTIII (X)

QT-III improves QT-II design with more integration features:

- ▶ Integrated mastic seal on the cable lug.
- ▶ Integrated stress control mastic at the end of the semi-conductive shield and improved stress control behavior.

QT-III also is made of new silicone rubber with 4 times better track resistance, which make it having faster hydrophobic recovery.

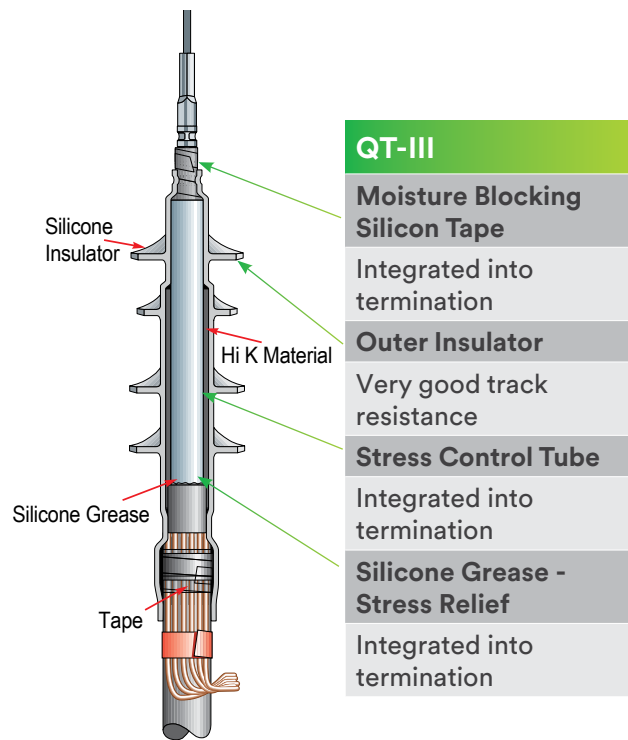

STRESS CONTROL

3M Cold Shrink QT-III Silicone Rubber Skirted and Inverted Skirted Termination Kits, 7620-S, 7680-S and 7690-S Series, control the electric field stress distribution with special High- K materials, which are an integral part of the termination. The High-K materials with a dielectric constant (K) of greater than 15, capacitively distribute the field that surrounds the termination.

The stress concentrations in a continuous length of shielded cable are typically 50 V/mil adjacent to the shield to about 70 V/mil at the conductor. The 3M Cold Shrink QT-III.

Silicone Rubber Termination reduces the cable stresses at the termination to less than those in the continuous shielded portion of the cable. Electrical flux is refracted to distribute the voltage stress in a controlled manner along the entire termination length extending beyond the cable shield cutoff. By controlling the electric field, the stress concentrations on the termination insulator surface are kept below 15 V/mil at rated voltage. This stress distribution permits high power frequency performance and impulse performance with a compact termination design.

Figure 1 below illustrates an actual computerized stress plot of the 3M Cold Shrink QT-III Silicone Rubber Termination.

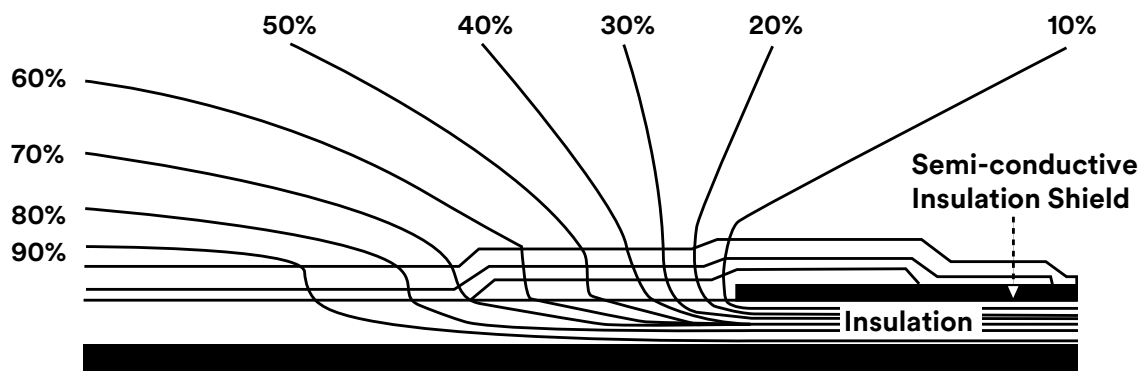

Figure 1

3M Cold Shrink QT-III Silicone Rubber Skirted and Inverted Skirted Termination Kit		System Voltage	Operating Environment			
			Light	Medium	Heavy	Extremely Heavy
2 Skirt	7620-S-2, 7621-S-2	5 & 8kV	✓	✓	✓	
2 Skirt	7622-S-2, 7622-S-2 (L)**, 7622-S-INV-2, 7622-S-INV-2 (L)**	15kV	✓	✓	✓	
4 Skirt	7692-S-4 - 7696-S-4, 7692-S-4 (L)**, 7695-S-4 (L)**, 7693-S-INV-4, 7695-S-INV-4, 7696-S- INV-4, 7695-S-INV-4 (L)**	15kV	✓	✓	✓	✓
8 Skirt	7683-S-8 - 7686-S-8, 7685-S-8 (L)**	15kV	✓	✓	✓	✓
4 Skirt	7692-S-4 - 7696-S-4, 7695-S-4 (L)**, 7693-S-INV-4, 7695-S-INV-4, 7695-S-INV-4 (L)**, 7696-S-INV-4	25/28kV	✓	✓	✓	
8 Skirt	7683-S-8 - 7686-S-8, 7685-S-8 (L)**	25/28kV	✓	✓	✓	✓
4 Skirt	7693-S-INV-4, 7695-S-INV-4, 7696-S-INV-4	35kV	✓	✓	✓	
8 Skirt	7683-S-8 - 7686-S-8	40.5kV	✓	✓	✓	*

Recommended operation environments are marked with a check (✓)

* Consult 3M sales representative

** The designated (L) version terminations are the same as the non-(L) versions of the above specified termination kits, except that they are on a larger core to accommodate and properly fit specific 3M Mechanical Shearbolt Lugs QL2 Series: Two-Hole and the Insulation O.D. range is slightly different than the non-(L) versions (See Termination Selection Table on Pages 9 and 10).

TYPICAL PROPERTIES

Not for specifications. Values are typical, not to be considered minimum or maximum. Properties measured at room temperature 73°F (23°C) unless otherwise stated.

3M Cold Shrink QT-III Silicone Rubber Skirted and Inverted Skirted Termination Kits, 7620-S, 7680-S and 7690-S Series can be used on cables with a rated maximum operating temperature of 221°F (105°C) and an overload rating of 284°F (140°C). Terminations constructed from these kits meet the requirements of IEEE Standard 48, "IEEE Standard Test Procedures and Requirements for High-Voltage Alternating-Current Cable Terminations" and are designated Class 1 for outdoor weather-exposed locations. The current rating of these terminations meets or exceeds the current rating of the cables on which they are installed.

TYPICAL DIMENSIONS

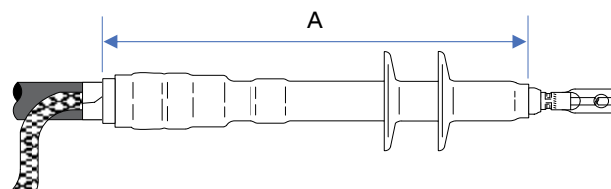

Kit Number	Dimension [A] (Max.)	Wet Creepage Distance (Max.)	Arcing Distance (Max.)
7620-S-2	10.5" (267 mm)	14.0" (356 mm)	10.5" (267 mm)
7621-S-2	10.5" (267 mm)	14.0" (356 mm)	10.5" (267 mm)
7622-S-2	9.8" (249 mm)	13.3" (338 mm)	9.8" (249 mm)
7622-S-2 (L)	9.8" (249 mm)	13.3" (338 mm)	9.8" (249 mm)

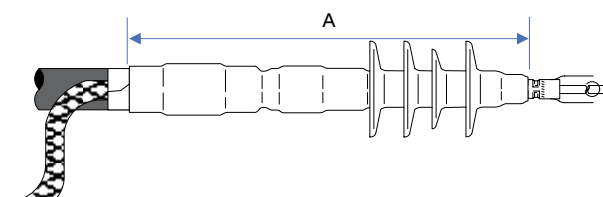

Kit Number	Dimension [A] (Max.)	Wet Creepage Distance (Max.)	Arcing Distance (Max.)
7692-S-4	12.25" (311 mm)	18.5" (470 mm)	12.25" (311 mm)
7692-S-4 (L)	12.25" (311 mm)	18.5" (470 mm)	12.25" (311 mm)
7693-S-4	12.25" (311 mm)	18.5" (470 mm)	12.25" (311 mm)
7694-S-4	12.25" (311 mm)	18.5" (470 mm)	12.25" (311 mm)
7695-S-4	12.25" (311 mm)	18.5" (470 mm)	12.25" (311 mm)
7695-S-4 (L)	12.25" (311 mm)	18.5" (470 mm)	12.25" (311 mm)
7696-S-4	13.25" (337 mm)	19.5" (495 mm)	13.25" (337 mm)

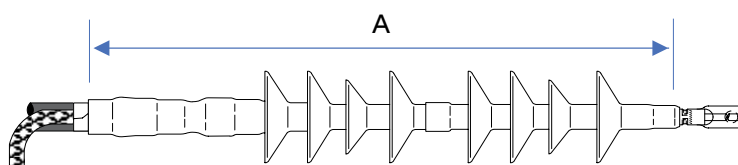

Kit Number	Dimension [A] (Max.)	Wet Creepage Distance (Max.)	Arcing Distance (Max.)
7683-S-8	20.50" (521 mm)	33.00" (838 mm)	20.50" (521 mm)
7684-S-8	20.50" (521 mm)	33.00" (838 mm)	20.50" (521 mm)
7685-S-8	20.50" (521 mm)	33.00" (838 mm)	20.50" (521 mm)
7685-S-8 (L)	20.50" (521 mm)	33.00" (838 mm)	20.50" (521 mm)
7686-S-8	21.50" (546 mm)	34.00" (864 mm)	21.50" (546 mm)



Medium Voltage Terminations

Heat Shrink Technology

MHO/MHI Series



PRODUCT DESCRIPTION

3M Heat Shrink Terminations up to 36KV, are specially designed for conditions where the terminations are exposed to precipitation, outdoor sunlight, extreme climatic variances and heavily polluted areas. The specially engineered kits also take care of the typical partial discharge and surface corona phenomenon for all power cables under challenging service conditions.

All components required for the termination are included in a single kit, which has a prolonged storage life under normal storage conditions. A few sizes of the kits cover the entire range of cables, helping in reducing inventories. The heat shrinkable components are light in weight and are made of a specially formulated cross-linked polymeric material with excellent tracking and erosion resistance characteristics. A proper creepage path is obtained within a short overall length of the termination. The kits have been designed to meet various international standards like IS, HDE, IEEE, IEC and BS. Our state-of-the-art manufacturing facility and in-house testing laboratories and accreditation to the ISO 9001 quality assurance standard, guarantees the performance of our materials to suit customer requirement.

3M Heat Shrink Terminations are available for both indoor and outdoor application. The terminations are available for single core and multi core cable types.

Indoor terminations: components are designed to withstand high humidity and surface contamination under electric stress caused due to condensation and dust in internal conditions.

Outdoor terminations: components are designed to withstand exposure to UV radiation, extreme climatic variations and surface contamination under electric stress caused due to condensation, pollution and dust in external condition.

PRODUCT APPLICATION

3M Heat Shrink medium voltage terminations are available for tape/wire shielded, armoured/unarmoured medium voltage single core and three core polymeric cables. 3M Heat Shrinkable terminations utilize a unique high dielectric constant (High K) stress control tube and mastic for effective grading of electrical stresses.



The non tracking heat shrinkable insulating outer tube is optimally designed for reliable environmental protection.

The modular heat shrinkable skirts allow installation of the termination in inverted condition if required. For three core cable terminations, a heat shrinkable breakout is provided for environment sealing of the trifurcating crotch area. All the heat shrinkable components are supplied in an expanded state and would shrink effectively on application of heat. All the grounding connections are solder-less.

Kit Description	Cable Insulation Outer Diameter Application range (mm)
MHI/MHO 24kV 35/50 SQMM ID c/w:	
Stress Control Tube 30/15	24 .. 18
Anti-Tracking Tube 35/12	28 .. 14.4
MHI/MHO 24kV 70/120 SQMM ID c/w:	
Stress Control Tube 45/20	36 .. 24
Anti-Tracking Tube 45/19	36 .. 22.8
MHI/MHO 24kV 150/300 SQMM ID c/w:	
Stress Control Tube 50/25	40 .. 30
Anti Tracking Tube 55/20	44 .. 24



PRODUCT FEATURES

- ▶ Available for 1-core and 3-core polymeric cables.
- ▶ Provides excellent environmental protection and moisture sealing.
- ▶ Wide conductor size ranges.
- ▶ Ease of installation.
- ▶ Simplified cable preparation.
- ▶ Outstanding long-term reliability.
- ▶ Effective and reliable stress control.
- ▶ Excellent mechanical, thermal and electrical characteristics.
- ▶ Superior resistance to weathering and UV.
- ▶ Resistant to water and corrosion.
- ▶ Immediate energization of cable on completion.

Test	Test Value	Result
Partial Discharge Test	Less than 10 pC at 22kV	Pass
5 min AC High Voltage Test	57kV	Pass
1 min AC High Voltage Test	65kV	Pass
Load Cycle Test, at 2.5 Uo	63 cycles	Pass
15 Min DC Withstand test	76kV	Pass
Impulse Voltage Test	150kVp	Pass

Medium Voltage Terminations

DETAIL OF PRODUCT TERMINATIONS FOR POLYMERIC CABLES

1. Terminal Lug (Not included in the kit)
2. Anti-Tracking sleeve
3. Rain Shed (skirt)
4. Stress Control Sleeve
5. Stress Control Mastic
6. XLPE Insulation
7. Constant Force Spring
8. Copper Braid
9. Trifurcating break out (adhesive coated)

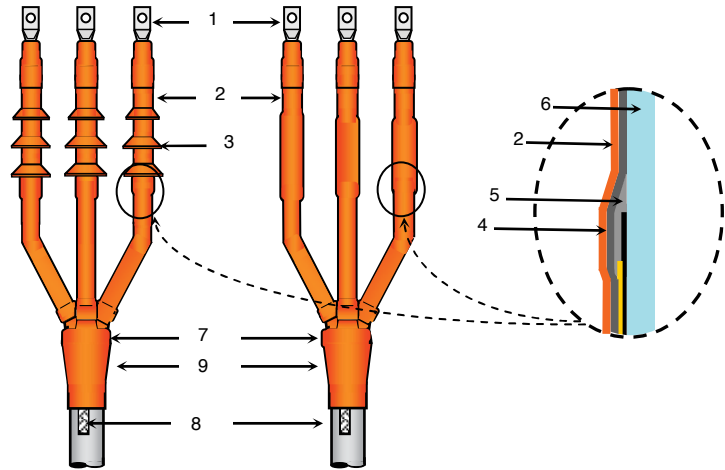

3 Core Terminations

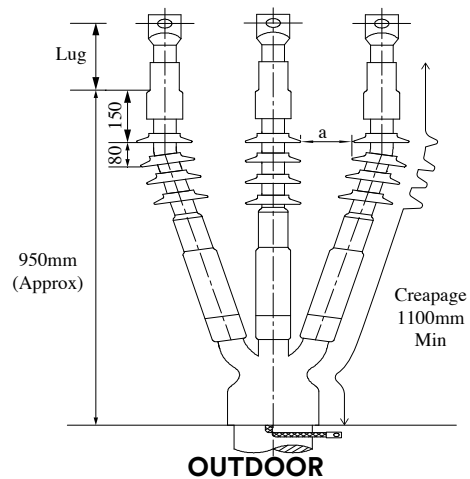
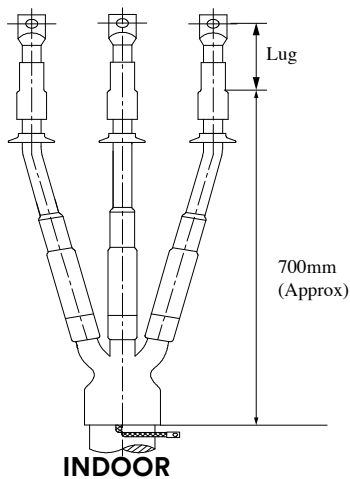

1 Core Terminations

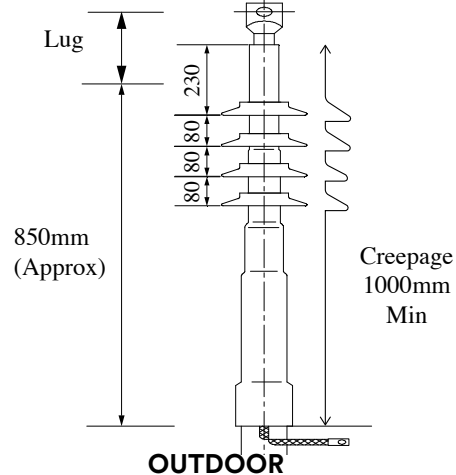
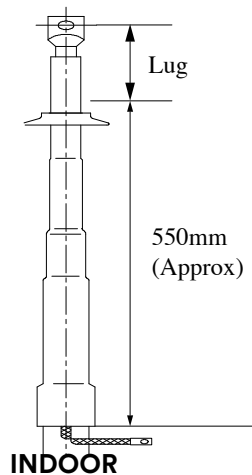

SELECTION GUIDE

No.	Product Description	Cable (mm ²)	Phase	Outdoor / Indoor	Voltage
1	MHI 24kV 1C-35/50 SQMM ID	35/50	1	Indoor	24kV
2	MHI 24kV 1C-70/120 SQMM ID	70/120	1	Indoor	24kV
3	MHI 24kV 1C-150/300 SQMM ID	150/300	1	Indoor	24kV
4	MHO 24kV 1C-35/50 SQMM OD	35/50	1	Outdoor	24kV
5	MHO 24kV 1C-70/120 SQMM OD	70/120	1	Outdoor	24kV
6	MHO 24kV 1C-150/300 SQMM OD	150/300	1	Outdoor	24kV
7	MHI 24kV 3C-35/50 SQMM ID	35/50	3	Indoor	24kV
8	MHI 24kV 3C-70/120 SQMM ID	70/120	3	Indoor	24kV
9	MHI 24kV 3C-150/300 SQMM ID	150/300	3	Indoor	24kV
10	MHO 24kV 3C-35/50 SQMM OD	35/50	3	Outdoor	24kV
11	MHO 24kV 3C-70/120 SQMM OD	70/120	3	Outdoor	24kV
12	MHO 24kV 3C-150/300 SQMM OD	150/300	3	Outdoor	24kV





**3M Scotchcast™
Resin 40**

3M United Kingdom PLC, 3M Centre, Cain Road, Bracknell, Berks., RG12 8HT, Tel: 01344 858 000.
3M Ireland Ltd, The Weigh Building, The Park, Carrickmines, Dublin 18. Tel: 01 2803555
3M France, Bd de l'Oise, 95006 Cergy Pontoise Cedex. Tel: 01 30 41 61 61
3M Deutschland GmbH, Carl-Schurz-Str.1, 41453 Neuss, Tel: (02131) 14 0
3M Österreich GmbH, Kranichberggasse 4, 1120 Wien, Tel: 01786 686 0
3M (Schweiz) GmbH, Eggstrasse 93, 8803 Rüschlikon. Tel: 044 724 90 90
3M Italia srl - Via N. Bobbio 21 - 20096 Poglietto (MI) - Tel: 02 70351
3M España, S.L. Juan Ignacio Luca de Tena 19-25, 28027 Madrid, Tel: (91) 3216000
3M Nederland B.V., Postbus 1002, 2600 BA Delft, Tel: (015)-7822333.
3M Belgium BVBA/SPRL, Herestraat, 7-1831 Diegem, Tel: 027722511

44-2001-3025-6 / MSDS: 28-3096-7 - 24/08/2017

Tape Resin Splices

VN-5B & 6B Series

PRODUCT DESCRIPTION

3M™ Splice Solutions are designed to help you reduce the time, labor and cost involved in a variety of electrical cable splicing applications.

When you want the versatility of tape, 3M™ Tape Resin Splice VN-5B & 6B series are the answer for almost any application, regardless of cable type or size. The splice kit comprises 3M™ Scotch® splicing tape and 3M™ Scotchcast™ Resin, which are designed for extra-long shelf life, so there's less chance of being caught without the supplies you need for emergencies. 3M™ Tape Resin Splice products are available to splice cables from 600V to 69kV.

The splicing kits have a high degree of mechanical strength for physical protection of connections and provide moisture-resistant insulation in above ground or direct burial applications.

PRODUCTION APPLICATION

A splice may be considered as two or more conductors joined with a suitable connector reinsulated, reshielded and re-jacketed with compatible materials applied over a properly prepared surface. Whenever possible, splicing is normally avoided. However splicing is often an economic necessity. There can be many reasons for building splices such as:

- ▶ The supplied length of cable is not sufficient to perform the intended job only so much cable can be wound on a reel (reel ends) ... only so much cable can be pulled through so much conduit, around so many bends, etc.
- ▶ Cable failures.
- ▶ Cables damaged after installation.
- ▶ A tap into an existing cable (tee or wye splices). In all the above cases, the option is to either splice the cable or replace the entire length. The economy of modern splicing products in many cases makes splicing an optimal choice.

Whatever the reason to splice, good practice dictates that splices have the same rating as the cable. In this way the splice does not derate the cable and become the weak link in the system.



FEATURE

- ▶ **Excellent environment seal:** the Scotchcast™ Resin provides impact resistance and durability against moisture and atmospheric corrosion.
- ▶ **Larger application range:** all splicing kits only have different quantity of tapes and resin bags which make large kit could be used for smaller size, increasing the availability in case of emergency.
- ▶ **Flexibility:** beside the inline joint, with knowledge, tape resin splicing kit could be adjusted to use for branch joint and jacket damaged repair.
- ▶ **Environment friendly:** 3M™ Scotchcast™ Resin is RoHS 2002/95/EC compliance.
- ▶ **Easy installation:** the resin bag now come with spout and opener B.

DETAILED INSTALLATION OF THE TAPE RESIN SPLICE

The six common steps in building a splice:

- ▶ Prepare surface
- ▶ Join conductors with connector(s)
- ▶ Strand reshield
- ▶ Reinsulate
- ▶ Insulation & metallic reshield
- ▶ Rejacket

It should be recognized that the greatest assurance against splice failure remains with the person who makes the splice. Adequate cable preparation, proper installation of all components and good workmanship require trained skills performed by people adept at them. Yet the expertise, skills and care of the installer are still necessary to make a dependable splice.

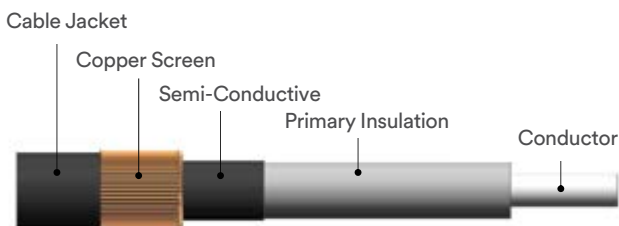

1. Prepare the surface

High quality products usually include detailed installation instructions. These instructions should be followed. A suggested technique is to check off steps as they are completed. Good instructions alone do not qualify a person as a “cable splicer”. Certain manufacturers offer “hands-on” training programs designed to teach proper installation of their products. It is highly recommended that inexperienced splice and termination installers take advantage of such programs where available.

2. Join conductors with connector

After the cables are completely prepared, the rebuilding process begins. The first step is reconstructing the conductor with a suitable connector. A suitable connector for high voltage cable splices is a compression or crimp type.

Aluminum conductor

Connect with aluminum-bodied connector (marked CU/AL). These must come pre-loaded with contact aid (anti-oxide paste) to break down the insulating aluminum oxide coating on both the connector and conductor surfaces.

Copper conductor

Connect with either copper or aluminum bodied connectors. It is recommended that a UL listed connector be used that can be applied with any common crimping tool. This connector should be tested and approved for use at high voltage. In this way, the choice of the high voltage connector is at the discretion of the user, and is not limited by the tools available.





3. Strand reshield

The cable's two shielding systems (strand shield and insulation shield system) must be rebuilt when constructing a splice. The cable strand shielding is replaced by a semiconductive tape. This tape is wrapped over the connector area to smooth the crimp indents and connector edges.

4. Reinsulate

The most versatile approach, tape, is not dependent upon cable types and dimensions. Tape has a history of dependable service and is generally available. However, wrapping tape on a high voltage cable can be time consuming and error prone since the careful build-up of tape requires accurate half-lapping and constant tension in order to reduce build-in air voids.



5. Insulation & metallic reshield

The insulation shielding system is replaced by a combination of tapes. Semi-con is replaced with the same semi-conducting tape used to replace the strand shield. The cable's metallic shield is generally replaced with a flexible woven mesh of tin plated copper braid. This braid is for electrostatic shielding only, and not designed to carry shield currents. For conducting shield currents, a jumper braid is installed to connect the cables metallic shields. This jumper must have an ampacity rating equal to that of the cables' shields.

6. Rejacket

The jacket is reconstructed by a combination of tapes and resin. P3F Spacer Tape is used to build up voids in odd shaped splices, ensures full resin coverage, and forms a liquid tight mould. The filament tape is used to increase the impact strength of the splice. The transparent tape provides outer layer to ensure safe and enclosed resin injection. The Scotchcast™ resin unique electrical and physical properties make it ideal for cable jacket replacement.



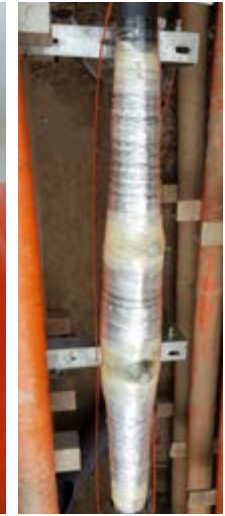
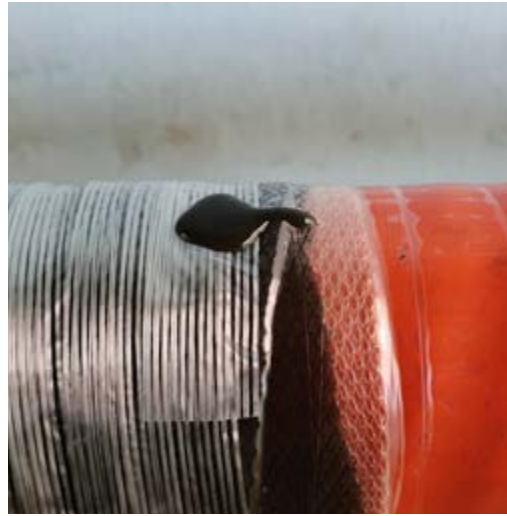

SELECTION GUIDE

1C XLPE/EPR amoured tape shield Cu cable, 24kV

No.	Product Description	Cable (mm ²)	Phase	Voltage
1	VN-5B-50-Cu/1	50	1	24kV
2	VN-5B-70-Cu/1	70	1	24kV
3	VN-5B-95-Cu/1	95	1	24kV
4	VN-5B-120-Cu/1	120	1	24kV
5	VN-5B-150-Cu/1	150	1	24kV
6	VN-5B-185-Cu/1	185	1	24kV
7	VN-5B-240-Cu/1	240	1	24kV
8	VN-5B-300-Cu/1	300	1	24kV
9	VN-5B-400-Cu/1	400	1	24kV
10	VN-5B-500-Cu/1	500	1	24kV
11	VN-5B-630-Cu/1	630	1	24kV

1C XLPE/EPR amoured tape shield AL cable, 24kV

No.	Product Description	Cable (mm ²)	Phase	Voltage
1	VN-5B-50-AL/1	50	1	24kV
2	VN-5B-70-AL/1	70	1	24kV
3	VN-5B-95-AL/1	95	1	24kV
4	VN-5B-120-AL/1	120	1	24kV
5	VN-5B-150-AL/1	150	1	24kV
6	VN-5B-185-AL/1	185	1	24kV
7	VN-5B-240-AL/1	240	1	24kV
8	VN-5B-300-AL/1	300	1	24kV
9	VN-5B-400-AL/1	400	1	24kV
10	VN-5B-500-AL/1	500	1	24kV
11	VN-5B-630-AL/1	630	1	24kV

3C XLPE/EPR amoured tape shield Cu cable, 24kV

No.	Product Description	Cable (mm ²)	Phase	Voltage
1	VN-5B-50-Cu/3	50	3	24kV
2	VN-5B-70-Cu/3	70	3	24kV
3	VN-5B-95-Cu/3	95	3	24kV
4	VN-5B-120-Cu/3	120	3	24kV
5	VN-5B-150-Cu/3	150	3	24kV
6	VN-5B-185-Cu/3	185	3	24kV
7	VN-5B-240-Cu/3	240	3	24kV
8	VN-5B-300-Cu/3	300	3	24kV
9	VN-5B-400-Cu/3	400	3	24kV
10	VN-5B-500-Cu/3	500	3	24kV

3C XLPE/EPR amoured tape shield AL cable, 24kV

No.	Product Description	Cable (mm ²)	Phase	Voltage
1	VN-5B-50-AL/3	50	3	24kV
2	VN-5B-70-AL/3	70	3	24kV
3	VN-5B-95-AL/3	95	3	24kV
4	VN-5B-120-AL/3	120	3	24kV
5	VN-5B-150-AL/3	150	3	24kV
6	VN-5B-185-AL/3	185	3	24kV
7	VN-5B-240-AL/3	240	3	24kV
8	VN-5B-300-AL/3	300	3	24kV
9	VN-5B-400-AL/3	400	3	24kV
10	VN-5B-500-AL/3	500	3	24kV

1C XLPE/EPR amoured tape shield Cu cable, 36kV

No.	Product Description	Cable (mm ²)	Phase	Voltage
1	VN-6B-50-Cu/1	50	1	36kV
2	VN-6B-70-Cu/1	70	1	36kV
3	VN-6B-95-Cu/1	95	1	36kV
4	VN-6B-120-Cu/1	120	1	36kV
5	VN-6B-150-Cu/1	150	1	36kV
6	VN-6B-185-Cu/1	185	1	36kV
7	VN-6B-240-Cu/1	240	1	36kV
8	VN-6B-300-Cu/1	300	1	36kV
9	VN-6B-400-Cu/1	400	1	36kV
10	VN-6B-500-Cu/1	500	1	36kV
11	VN-6B-630-Cu/1	630	1	36kV

1C XLPE/EPR amoured tape shield AL cable, 36kV

No.	Product Description	Cable (mm ²)	Phase	Voltage
1	VN-6B-50-AL/1	50	1	36kV
2	VN-6B-70-AL/1	70	1	36kV
3	VN-6B-95-AL/1	95	1	36kV
4	VN-6B-120-AL/1	120	1	36kV
5	VN-6B-150-AL/1	150	1	36kV
6	VN-6B-185-AL/1	185	1	36kV
7	VN-6B-240-AL/1	240	1	36kV
8	VN-6B-300-AL/1	300	1	36kV
9	VN-6B-400-AL/1	400	1	36kV
10	VN-6B-500-AL/1	500	1	36kV
11	VN-6B-630-AL/1	630	1	36kV

3C XLPE/EPR amoured tape shield Cu cable, 36kV

No.	Product Description	Cable (mm ²)	Phase	Voltage
1	VN-6B-50-Cu/3	50	3	36kV
2	VN-6B-70-Cu/3	70	3	36kV
3	VN-6B-95-Cu/3	95	3	36kV
4	VN-6B-120-Cu/3	120	3	36kV
5	VN-6B-150-Cu/3	150	3	36kV
6	VN-6B-185-Cu/3	185	3	36kV
7	VN-6B-240-Cu/3	240	3	36kV
8	VN-6B-300-Cu/3	300	3	36kV
9	VN-6B-400-Cu/3	400	3	36kV
10	VN-6B-500-Cu/3	500	3	36kV

1C XLPE/EPR amoured tape shield Cu cable, 40.5kV

No.	Product Description	Cable (mm ²)	Phase	Voltage
1	VN-6BH-50-Cu/1	50	1	40.5kV
2	VN-6BH-70-Cu/1	70	1	40.5kV
3	VN-6BH-95-Cu/1	95	1	40.5kV
4	VN-6BH-120-Cu/1	120	1	40.5kV
5	VN-6BH-150-Cu/1	150	1	40.5kV
6	VN-6BH-185-Cu/1	185	1	40.5kV
7	VN-6BH-240-Cu/1	240	1	40.5kV
8	VN-6BH-300-Cu/1	300	1	40.5kV
9	VN-6BH-400-Cu/1	400	1	40.5kV
10	VN-6BH-500-Cu/1	500	1	40.5kV

1C XLPE/EPR amoured tape shield AL cable, 40.5kV

No.	Product Description	Cable (mm ²)	Phase	Voltage
1	VN-6BH-50-AL/1	50	1	40.5kV
2	VN-6BH-70-AL/1	70	1	40.5kV
3	VN-6BH-95-AL/1	95	1	40.5kV
4	VN-6BH-120-AL/1	120	1	40.5kV
5	VN-6BH-150-AL/1	150	1	40.5kV
6	VN-6BH-185-AL/1	185	1	40.5kV
7	VN-6BH-240-AL/1	240	1	40.5kV
8	VN-6BH-300-AL/1	300	1	40.5kV
9	VN-6BH-400-AL/1	400	1	40.5kV
10	VN-6BH-500-AL/1	500	1	40.5kV

3C XLPE/EPR amoured tape shield Cu cable, 40.5kV

No.	Product Description	Cable (mm ²)	Phase	Voltage
1	VN-6BH-50-Cu/3	50	3	40.5kV
2	VN-6BH-70-Cu/3	70	3	40.5kV
3	VN-6BH-95-Cu/3	95	3	40.5kV
4	VN-6BH-120-Cu/3	120	3	40.5kV
5	VN-6BH-150-Cu/3	150	3	40.5kV
6	VN-6BH-185-Cu/3	185	3	40.5kV
7	VN-6BH-240-Cu/3	240	3	40.5kV
8	VN-6BH-300-Cu/3	300	3	40.5kV
9	VN-6BH-400-Cu/3	400	3	40.5kV
10	VN-6BH-500-Cu/3	500	3	40.5kV

3C XLPE/EPR amoured tape shield AL cable, 40.5kV

No.	Product Description	Cable (mm ²)	Phase	Voltage
1	VN-6BH-50-AL/3	50	3	40.5kV
2	VN-6BH-70-AL/3	70	3	40.5kV
3	VN-6BH-95-AL/3	95	3	40.5kV
4	VN-6BH-120-AL/3	120	3	40.5kV
5	VN-6BH-150-AL/3	150	3	40.5kV
6	VN-6BH-185-AL/3	185	3	40.5kV
7	VN-6BH-240-AL/3	240	3	40.5kV
8	VN-6BH-300-AL/3	300	3	40.5kV
9	VN-6BH-400-AL/3	400	3	40.5kV
10	VN-6BH-500-AL/3	500	3	40.5kV

Cold Shrink

Inline Joint

with Heat-Shrink re-jacketing

3M™ QS 2000E Series



PRODUCT DESCRIPTION

3M™ Splice Solutions are designed to help you. The 93-AS 220-1(3) Inline Joint Series includes single or three core Cold Shrink QS 2000E silicone splice bodies with integrated stress control device, silicone elastomer insulation and outer semi-conductive layer. Also included are Scotch® 13 tape, to form the inner conductive electrode, copper screen sleeve, constant force springs, screen wire connector for earth connection and heavy-duty Heat Shrink outer tubes with mastic seal tapes to re-build the cable outer jacket.

PRODUCTION APPLICATION

The 3M QS 2000E Cold Shrink Series Kits are designed for inline splicing up to 24kV Umax voltage class, Single core or Three core polymeric power cable systems with common copper wire screen according to HD 620 (IEC 60502).

Splicing medium voltage power cables of different voltages classes and cross sections is possible.

Use of silicone material which has proven in medium voltage and High Voltage application.

- ▶ Dual layer extrusion with painted, vulcanized, outer layer.
- ▶ One piece construction on removable supporting core.
- ▶ Cold Shrink technology for quick, easy and safe installation.
- ▶ Refractive stress control layer ensures evenly distribution of the electrical field over the entire splice area.
- ▶ Wide cross section application range.
- ▶ Construction of electrode with Scotch® 13 Tape.
- ▶ Accommodates crimp and mechanical connectors.
- ▶ No flame to use during splice body installation.
- ▶ No special tools needed.
- ▶ Excellent cold temperature shrinking behavior.
- ▶ Meets CENELEC & IEC standard.

Application	QS 2000E	Voltage Class				
	Technical Information	(According to Cenelec Standard)				
	Kit Coding	Portfolio Overview	6/10 kV	6.3/11 kV	8.7/15 kV	12.7/22 kV
1-core Polymeric Full Cold Shrink		92-AS 610-1 92-AS 620-1 92-AS 630-1			93-AS 620-1 93-AS 630-1	
1-core Polymeric Heat Shrink Re-jacketing		92-AS 210-1 92-AS 220-1 92-AS 230-1			93-AS 220-1 93-AS 230-1	
1-core Polymeric Resin Re-jacketing		92-AS 410-1 92-AS 420-1 92-AS 430-1			93-AS 420-1 93-AS 430-1	
3-core Polymeric Full Cold Shrink		92-AS 610-3 92-AS 620-3			93-AS 620-3	
3-core Polymeric Heat Shrink Re-jacketing		92-AS 210-3 92-AS 220-3			93-AS 220-3	
3-core Polymeric Resin Re-jacketing		92-AS 410-3 92-AS 420-3			93-AS 420-3	

Application Range						
Kit Ref.	Cable Dimensions for Polymeric Cables				Connector Dimensions	
	Diameter over cable jacket max. (mm)	Diameter over Primary Insulation (mm)	Cross Section (mm ²)		Diameter max. (mm)	Length max. (mm)
			6/10(12) kV	12.7/22(24) kV		
93-AS 220-1	46	19.1 - 36.8	95 - 300	50 - 300	38	170
93-AS 230-1	74	33.4 - 67.6	500 - 1000	400 - 1000	60	270
93-AS 220-3		19.1 - 36.8	95 - 300	50 - 300	38	170
93-AS 230-3		33.4 - 67.6	400 and above	400 and above	60	270

FEATURES

- ▶ The versatile design of the prefabricated one-piece cold shrink splice body allows installation on a wide range of cable sizes and types.
- ▶ Fast and easy installation at temperatures ranging from -20°C to + 50°C.
- ▶ No heat or flame needed during splice body installation.
- ▶ Accommodates crimp or mechanical connectors up to 38mm diameter and 170mm length.
- ▶ Wide application range covering cable cross sectional areas from 50mm² - 300mm² **.
- ▶ Solderless earth connection by means of copper screen sleeve and constant force springs.
- ▶ Thick walled, heavy duty Heat Shrink outer re-jacketing tubes with mastic seal tapes provide physical protection and moisture sealing of the completed Inline Splices.
- ▶ No special tools needed during splice installation.



DETAILED INSTALLATION OF THE QS 2000E

The 3M Cold Shrink technology ensures quick, easy and safe installation of the QS 2000E Splice Body by pulling and unwinding the plastic support core in counter clockwise direction. The use of special tools is not necessary.

Detailed instructions for installing the 3M QS 2000E Series Inline Joints are included in each kit.



SELECTION GUIDE

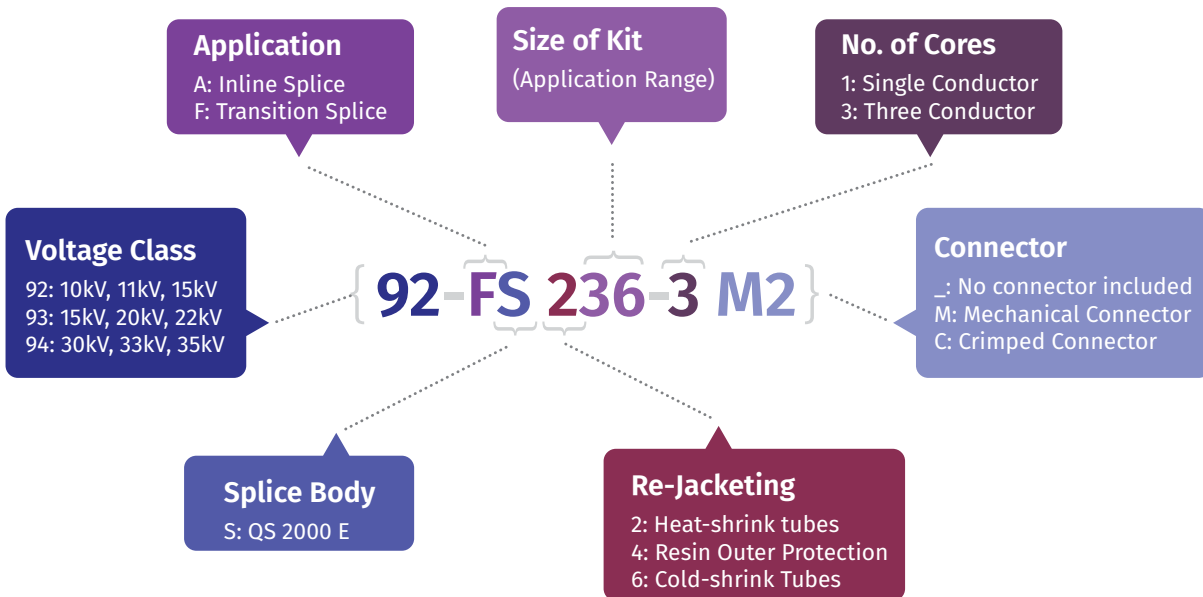

No.	Product Description	Cable (mm ²)	Phase	Voltage
1	24kV QS2000E-93-AS210-1C-35-70	35 - 70	1	24kV
2	24kV QS2000E-93-AS220-1C-95-120	95 - 120	1	24kV
3	24kV QS2000E-93-AS220-1C-150-300	150 - 300	1	24kV
4	24kV QS2000E-93-AS220-1C-240-400	240 - 400	1	24kV
5	24kV QS2000E-93-AS220-3C-50/120	50 - 120	3	24kV
6	24kV QS2000E-93-AS220-3C-150/300	150 - 300	3	24kV
7	24kV QS2000E-93-AS220-3C-240/400	240 - 400	3	24kV



Cold Shrink

Inline Joint

3M™ QS 200



PRODUCTION DESCRIPTION

The 3M QS 200 is a cold shrink, one-piece multilayer silicone rubber splice body with integrated electrode, stress control device, insulation and outer semi-conductive layer.

The 3M QS 200 silicone splice body is delivered on a removeable plastic supporting core.



During the installation the ribbon core is unwound counter clockwise, allowing the splicebody to shrink onto the cable joint. The applied permanent radial pressure guarantees a reliable function over the entire lifetime.

SPLICE BODY CONSTRUCTION

- ▶ The outer semi-conductive layer re-establishes the cable screen.
- ▶ The insulation of the splice body replaces the cable insulation across the entire splice.
- ▶ The integrated stress control element provides the proper electric field distribution.
- ▶ The integrated, semi-conductive electrode forms a faraday cage over the connector.

FEATURES

The versatile design of the prefabricated one-piece splice bodies allows installation on a wide range of cable sizes and types.

- ▶ Designed to fit all standard mechanical and compression connectors.
- ▶ Cold Shrink technology ensures quick, easy and tool-free installation.
- ▶ Excellent material properties allow the installation of the cold shrink splice body at temperatures ranging from -20°C to +50°C.
- ▶ Meets and exceeds CENELEC standard HD 629, as well as IEC 60502-4
- ▶ The integrated, semi-conductive electrode forms a faraday cage over the connector and eliminated the use of tapes or additional molded or metallic electrodes.
- ▶ No heat or flame is needed during splice body installation.
- ▶ Delivered mechanical connector provides an adequate application range.
- ▶ Solderless earth connection by means of copper screen sleeve and constant force springs.
- ▶ Thick walled, medium heat shrinkable outer re-jacketing tubes provide physical protection and moisture sealing of the completed Inline Splices. They can be stacked together providing a short parking position on the cable.
- ▶ No special tools needed during splice installation.

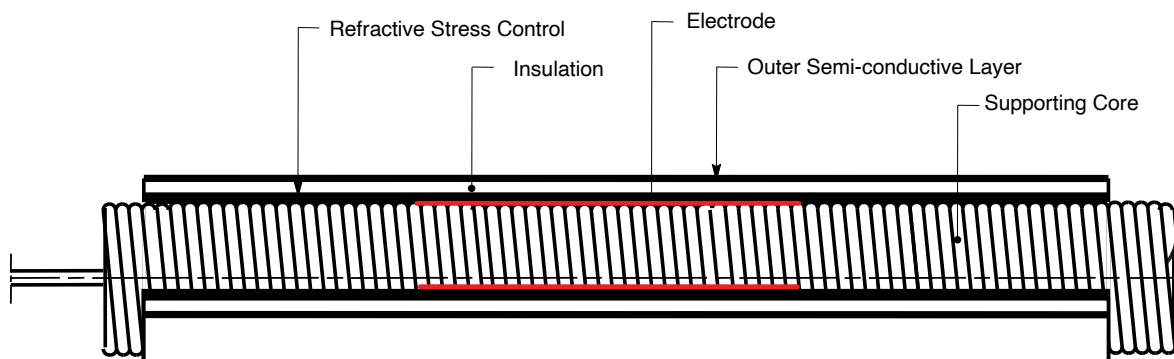



APPLICATIONS

3M QS 200 Cold Shrink Series Kits are designed for inline splicing up to 36kV Umax voltage class, single core & three core polymeric power cable systems with copper wire screen according to HD 620 (IEC 60502). Splicing medium voltage power cables of different voltage classes and cross sections is possible.

3M QS 200 Cold Shrink Series Kits includes the Cold Shrink QS 200 silicone splice body with integrated electrode, stress control device, silicone elastomer insulation and outer semi-conductive layer. Also included are connectors, copper screen sleeve, constant force springs. For rebuild the cable outer jacket with 3 options: EPDM rubber Cold Shrink outer tubes, Heat shrinkable outer tubes or Resin Re-jacketing.

Application Range						
Kit Ref.	Cable Dimensions for Polymeric Cables				Connector Dimensions Crimp or Mechanical Connector	
	Diameter over Cable jacket max.(mm)	Diameter over Primary Insulation (mm)	Cross Section (mm ²)		Diameter max. (mm)	Length max. (mm)
			12/20(24)kV 12,7/22(24)kV	12/20(24)kV 12,7/22(24)kV		
QS200 93-AK 220-1(3)	46	19,1 - 38	50 - 300		38	160
QS200 93-AK 230-1(3)	74	33,4 - 66	400 - 630		68	245
QS200 94-AK 220-1(3)	46	19,1 - 38		35 - 240	38	160
QS200 94-AK 230-1(3)	74	33,4 - 66		300 - 500	68	245
QS200 93-AK 420-1(3)	46	19,1 - 38	50 - 300		38	160
QS200 93-AK 430-1(3)	74	33,4 - 66	400 - 630		68	245
QS200 94-AK 420-1(3)	46	19,1 - 38		35 - 240	38	160
QS200 94-AK 430-1(3)	74	33,4 - 66		300 - 500	68	245



PRODUCT TEST

Tests conducted in accordance with CENELEC HD 629.1 S2

Maximum Voltage Class (Um):	24kV	36kV
AC 5 Minute Voltage Withstand:	57kV	85.5kV
AC 15 Minute Voltage Withstand:	32kV	47.5kV
DC 15 Minute Voltage Withstand:	76kV	114kV
Impluse voltage test:	125kV	194kV
Thermal Short Circuit (Screen, 2 stresses.)	5.1 kA/2s	5.1 kA/2s
Short Circuit Test (Conductor, 2 stresses.)	250°C	250°C

SELECTION GUIDE

QS 200 Technical Information	Portfolio Overview	Kit Coding / Voltage Class			
		12/20(24)kV	12,7/22(24)kV	19/33(36)kV	20/35(36)kV
Application	1-core Polymeric Full Cold Shrink	QS200 93-AK 620-1 QS200 93-AK 630-1		QS200 94-AK 620-1 QS200 94-AK 630-1	
	1-core Polymeric Heat Shrink Re-jacketing	QS200 93-AK 220-1 QS200 93-AK 230-1		QS200 94-AK 220-1 QS200 94-AK 230-1	
	1-core Polymeric Resin Re-jacketing	QS200 93-AK 420-1 QS200 93-AK 430-1		QS200 94-AK 420-1 QS200 94-AK 430-1	
	3-core Polymeric Heat Shrink Re-jacketing	QS200 93-AK 220-3 QS200 93-AK 230-3		QS200 94-AK 220-3 QS200 94-AK 230-3	
	3-core Polymeric Resin Re-jacketing	QS200 93-AK 420-3 QS200 93-AK 430-3		QS200 94-AK 420-3 QS200 94-AK 430-3	



Cold Shrink

Inline Joint

QS 3000 Series

PRODUCT DESCRIPTION

3M QS 3000 cold shrink splices are provided in the expanded state, mounted on removable inner supporting plastic cores. The cold shrink type splices are very easy for installation, only need to withdraw the supporting cores. QS 3000 splices are integral preforming type, the splice bodies are made of high quality liquid silicon rubber. Every splice does factory electrical test to insure reliable quality, the splices according to the Chinese standard GB/T 12706.4, IEC 60502-4 and are applicable for 26/35(40.5) kV & 20/35(40.5) kV extruded insulation power cables.

QS3000 have two types: straight splices QS 3000-K and insulated splices QS3000-AX applied in 1-C cable cross-link grounding system.



KIT CONTENTS

- ▶ Silicon rubber splice body
- ▶ Grounding braid wire
- ▶ Cable preparation kit
- ▶ Constant force spring
- ▶ Copper shielding sleeve
- ▶ 2228# insulating & waterproof tape (only c/w Armormat tape)
- ▶ 23# insulating tape
- ▶ 13# semi-conducting tape
- ▶ Armormat tape or Heat shrink / Cold shrink EPDM Tube or Resin Rejacketing

FEATURES

- ▶ Special copper shielding sleeve design, which could uniformize the electrical stress at the metallic connecting tube location.
- ▶ Enhanced insulation thickness, which is 16mm, and the AC voltage withstand margin up to 160kV.
- ▶ Optimized stress cone design ensures reliable electrical stress control performance.
- ▶ Cold shrink technology ensures quick, easy and tool-free installation.
- ▶ One-piece versatile design, have straight splice and insulating splice two types, allowing quick installation and accommodating a wide range of cable sizes.
- ▶ Seals tight, retains its resiliency and pressure even after years of aging and exposure.
- ▶ Wide temperature range.
- ▶ High contact pressure ensures absolute watertightness.
- ▶ Apply constant force spring to install grounding wires, ensures reliable contact performance.
- ▶ Flexible Rejacketing type: Special Armormat tape ensures reliable mechanical protection, or Conventional Heat shrink / Cold Shrink Rejacketing, or water seal tight Resin Rejacketing.
- ▶ 100% production tested.



QS 3000 Series

APPLICATIONS

Applicable for 26/35(40.5) kV & 20/35(40.5) kV extruded insulation cable, such as: Polyethylene (high and low density), cross-linked polyethylene (XLPE) and ethylene propylene rubber (EPR).

Applicable for overhead cables, buried cables, bridge cable and tunnel cables.

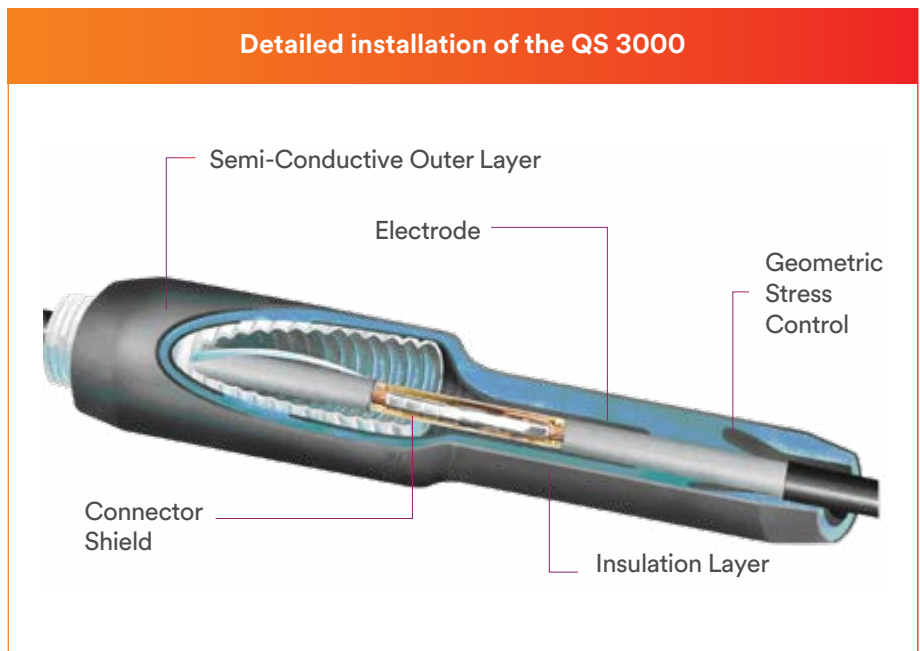

Copper shielding sleeve type	Suited metallic connecting tube maximum length (mm)	Suited metallic connecting tube maximum outer diameter (mm)
CS 50 ~ 95 mm ²	110	21
CS 120 ~ 185 mm ²	125	27
CS 240 ~ 400 mm ²	150	38
CS 500 ~ 630 mm ²	160	45

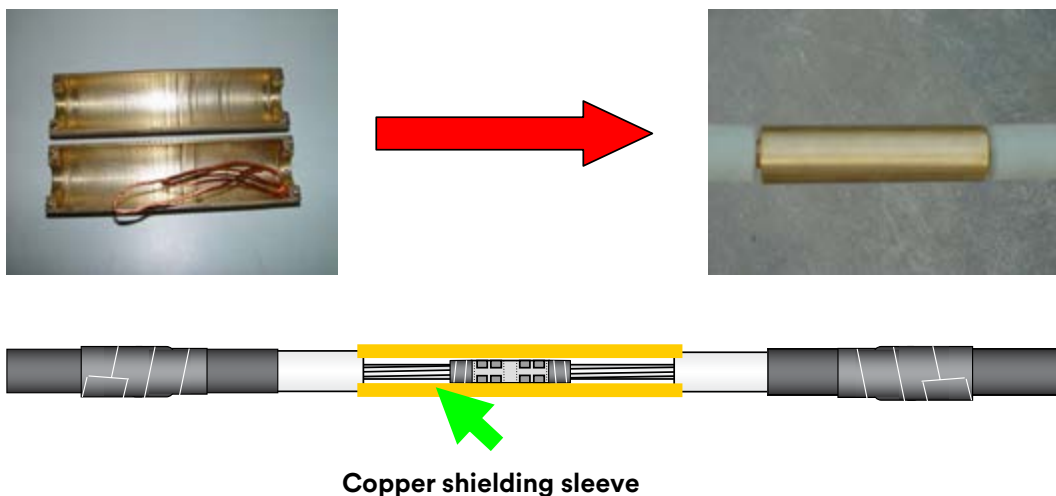

TYPICAL DIMENSIONS

Figure 1 Straight splice body on the score

Type	A (mm)	B (mm)	C (mm)	D (mm)	E (mm)
QS 3000-K1/QS 3000-I	455	30 ~ 50	30 ~ 50	61	≥100
QS 3000-K2/QS 3000-II	510	30 ~ 50	30 ~ 50	72	≥100

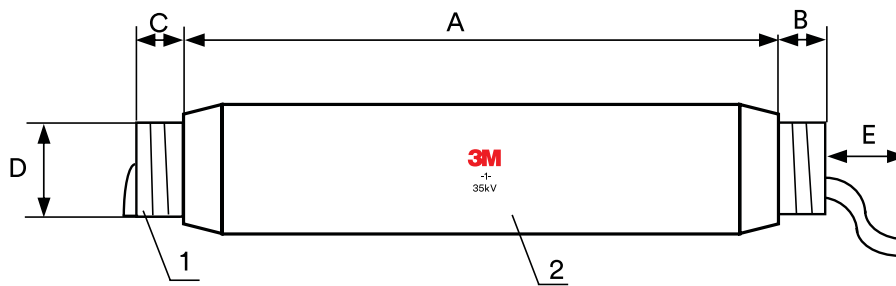

1/ Core 2/ Splice body

Figure 2 Straight splice body cross-section

Type	F (mm)	G (mm)	H (mm)	I (mm)	J (mm)	K (mm)
QS 3000-K1/QS 3000-I	509	21	53	75	102	218
QS 3000-K2/QS 3000-II	579	28	60	82	102	288

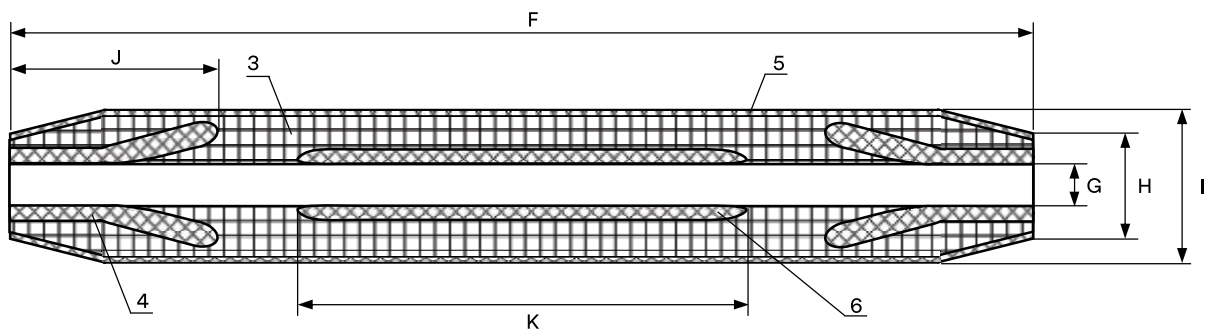

3/ Insulation layer 4/ Stress cone 5/ Outer semi-conductive layer 6/ Inner electrode

Figure 3 Insulated splice body on the core

Type	A (mm)	B (mm)	C (mm)	D (mm)	E (mm)
QS3000-AX	510	30 ~ 50	30 ~ 50	72	≥100

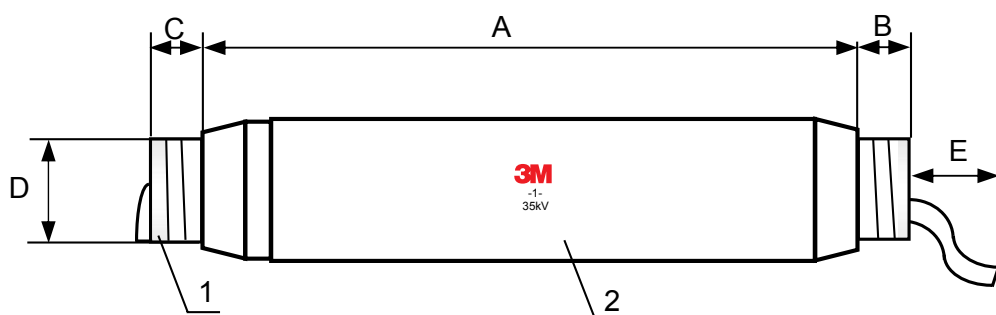

1/ Core 2/ Splice body

Figure 4 Insulated splice body cross-section

Type	F (mm)	G (mm)	H (mm)	I (mm)	J (mm)	K (mm)	L (mm)
QS 3000-AX	579	28	60	82	102	288	504

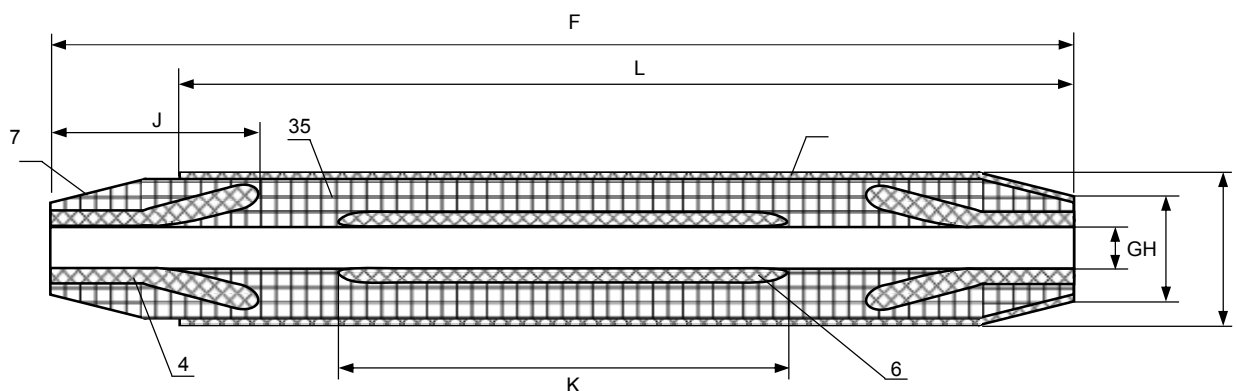

3/ Insulation layer 4/ Stress cone 5/ Outer semi-conductive layer 6/ Inner electrode
 7/ Shield Insulated Separation

SELECTION GUIDE

QS 3000 Straight Splices

Type (3-C/1-C)	Cable dimensions		
	Outer Cable Insulation diameter (mm)	20/35(40.5) kV	26/35(40.5) kV
QS 3000-K1/QS 3000-I	27.3 - 42.0	50 - 240	50 - 185
QS 3000-K2/QS 3000-II	36.4 - 57.2	300 - 800	240 - 630

QS 3000 Insulated Splices

Type (1-C)	Cable dimensions		
	Outer Cable Insulation diameter (mm)	20/35(40.5) kV	26/35(40.5) kV
QS 3000-AX	36.4 - 57.2	300 - 800	240 - 630

NOTE: The external diameter of the insulation layer is determinant, the cross-section of the conductor is only for reference.





IMPORTANT NOTICE TO PURCHASER

All statements, technical information and recommendations related to the Seller's products are based on information believed to be reliable, but the accuracy or completeness thereof is not guaranteed. Before utilizing the product, the user should determine the suitability of the product for its intended use. The user assumes all risks and liability whatsoever in connection with such use.

Any statements or recommendations of the Seller which are not contained in the Seller's current publications shall have no force or effect unless contained in an agreement signed by an authorized officer of the Seller. The statements contained herein are made in lieu of all warranties expressed or implied, including but not limited to the implied warranties of merchantability and fitness for a particular purpose which warranties are hereby expressly disclaimed.

SELLER SHALL NOT BE LIABLE TO THE USER OR ANY OTHER PERSON UNDER ANY LEGAL THEORY INCLUDING BUT NOT LIMITED TO NEGLIGENCE OR STRICT LIABILITY, FOR ANY INJURY OR FOR ANY DIRECT, INDIRECT, SPECIAL, INCIDENTAL OR CONSEQUENTIAL DAMAGES SUSTAINED OR INCURRED BY REASON OF THE USE OF ANY OF THE SELLER'S PRODUCTS



3M Vietnam Ltd.

20F, Maple Business Centre Building
1060 Nguyen Van Linh Street, Tan Phong Ward,
District 7, Ho Chi Minh City, Vietnam
Tel: (84.28) 5416 0429 | Fax: (84) 28 5416 0430

Hanoi Office

15F, Gelex Tower
52 Le Dai Hanh Street, Hai Ba Trung Ward,
Hanoi, Vietnam
Tel: (84.24) 3933 3780 | Fax: (84) 24 3933 3775

<http://www.3m.com.vn>